

ADDITIONAL WINDOWS NOT PART OF THE WALKING TOUR

Windows in Tower

The windows in the Tower contain various Christian symbols, e.g.: The interwoven “X and P” or the first two letters of the Greek word for “Christ;” The Cross with the word: “Nika,” Greek for: Victory, since through the Cross, Christ won the victory over the world and the devil; I H S, or the first three letters of the word “Jesus” in Greek; The Alpha and Omega, the first and the last letters of the Greek alphabet, signifying that Christ is the beginning, and the end, of all things; Apocalypse 1, 8.

Windows in Sacristy

The windows in the priests’ sacristy represent Christ’s 12 Apostles, whose successors are the bishops and priests of the Church: they continue to offer the Eucharistic Sacrifice, as they were commissioned to do by Christ. The Church is Christ. Not the Christ who died 2000 years ago. But, the Christ who rose from the grave, and truly lives in the Church, among His people, on the altar, priest and sacrifice forever. That is the story the windows bring home to every worshipper who contemplates them reverently and prayerfully.

Windows in Blessings Gift Shop

In Blessings Gift Shop (formerly the Baptistry), on your right as you enter the church from the south, are pictured two scenes explaining the use for which that room was first set aside: John baptizing his followers, who signified thereby that they were willing to do penance: *Matthew 3, 8* and John baptizing Christ: “And lo the heavens were opened to him: and he saw the spirit of God descending as a dove upon him. And behold a voice from heaven saying: ‘This is my beloved Son in whom I am well pleased’.” *Matthew 3, 13-17*.

SYMPHONY IN COLORS

The fascination of stained glass is in the ever-varying symphony of colors and shadings, that changing sunlight plays on the fundamental tones of red and blue and gold in the windows.

To see them at their best, view them at different hours of the day, and watch them, now sparkling and jewel-like, then solemn and mysteriously glowing, taking on new tints before your eyes.

RESTORATION

Our historic stained glass windows were restored in 2019-2020 thanks to gracious sponsors in support of our *Today Together Tomorrow* Capital Campaign.

FOR MORE INFORMATION:

www.sacredheartmoline.org

1608 13th Street, Moline IL 61265
shchurch@sacredheartmoline.org
(309) 762-2362



SACRED HEART
CATHOLIC CHURCH
MOLINE, ILLINOIS

STAINED GLASS WINDOWS WALKING TOUR

On entering the church, your eyes fall at once on the altar, and on the window above it (window #12): Considered together, they make clear that the Mass, offered on the altar, is the identical sacrifice Christ offered at the Last Supper (pictured in the lower panel of the window), and on the cross (upper part of the window).

The Eucharistic Sacrifice is offered to the triune God. Hence, above Christ on the cross the Holy Spirit is pictured in the symbol of the dove: *Matthew 3, 13-17*; and above is God the Father.

At the foot of the cross stands Mary, the Mother of Jesus, and John. Mary Magdalen is kneeling: *John 19, 25*. Two angels, under the arms of the cross, hold cups into which trickle drops of blood from the wounds in Christ’s hands: the representation is symbolic. Calvary means ‘place of the skull:’ hence, the skull at the foot of the cross.

To the right and left of the cross are pictured events connected with the crucifixion: the darkened sun; the moon appearing in the sky: *Mark 16, 33*. In the panels at the bottom: on the left, the buildings of Jerusalem are outlined in the gathering gloom; on the right the graves open and the dead arise: *Matthew 22, 51-52*.

Higher up, on the left, are pictured Adam and Eve, driven out of Paradise, and the angel with the flaming sword standing guard at the entrance: *Genesis 3, 23-24*. Through His death on the cross, Christ freed us from our sin: *Romans 5, 12-19*.

Still higher up, in the tracery on the left, are angels. Some hold symbolic shields, like the one holding the shield with the Lamb of God: *Isaiah 16, 1*; others are in attitudes of adoration.

In the panel on the right, an angel holds the veil of Veronica, on which Christ imprinted his features. Above is a shield representing Mary; and a lily, symbol of her purity as Christ's Mother-to-be. Still higher are more angels, some holding shields with the instruments of the passion: the cross, the crown of thorns, the nails.

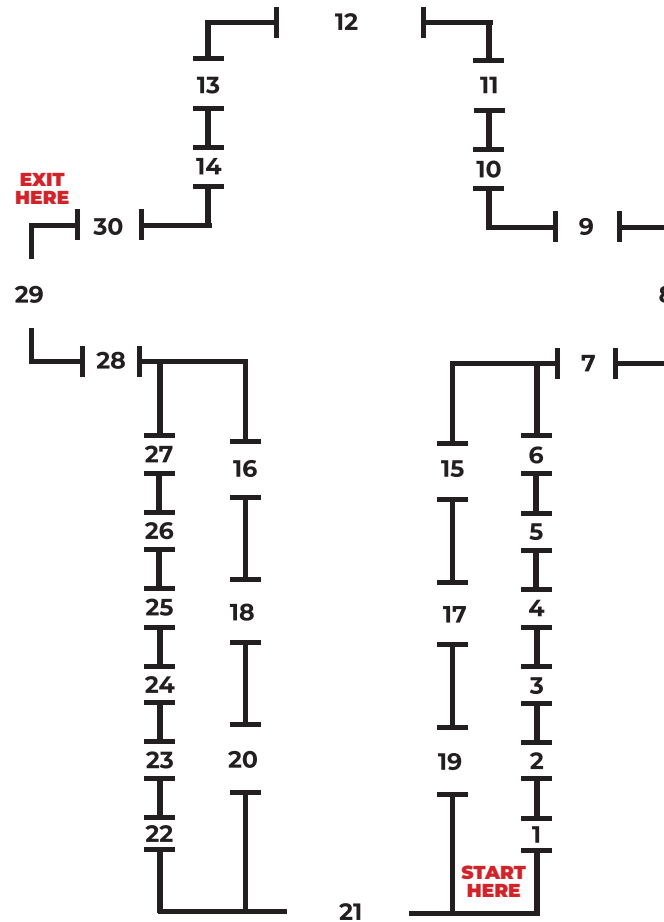

1. The Healing of the Leper
2. The Healing of the Man Possessed
3. The Healing of the Paralytic
4. The Raising of Lazarus
5. Jesus Stills the Storm on Lake Genesareth
6. The Healing of the Woman with Hemorrhages
7. The Finding of Jesus in the Temple
8. The Nativity
9. The Annunciation
10. The Sacrifice of Melchizedek
11. The Feeding of the Multitudes
12. The Crucifixion
13. The Exodus
14. The Passover
15. Jesus Returning to Jerusalem
16. Jesus in the Garden of Gethsemane
17. Mary Washing the Feet of Jesus
18. Jesus and the Children
19. The Assumption
20. The Ascension
21. The Resurrection
22. The Rich Young Man
23. The Sower
24. Pharisee and the Tax Collector
25. The Good Samaritan
26. The Prodigal Son
27. The Good Shepherd
28. The Presentation
29. The Visitation
30. The Angel Gabriel Appearing to Zachariah

The Resurrection of Christ window (window #21) in the south wall, above the gallery, the largest in the church, is 35 feet high. Its importance lies in the fact that, by His Resurrection, Christ proved that He was the Son of God, the master of life and death. *Matthew 18: 1-15*.

He Himself foretold it: *Matthew 17: 22*; and hence the inscription reads: "He rose as He said;" holding aloft the banner of victory.

On the sides of the rising Christ, you see: the angel moving away the stone from the grave; and the guards falling to the ground, blinded and terrified: *Matthew 28: 4*. The two blue panels at the bottom of this window represent two symbols of Christ's Resurrection: on the left is the story of Jonas and the whale: *Jonas 2: 1-11*, which Christ Himself used: *Matthew 12: 39-40*; *Luke: 11, 29-32*. On the right is the story of Samson carrying away the gates of the Philistine city: *Judges 16: 1-3*, as Christ carried away the doors of death.